

# microSHIFT

## Cassette User Manual

# CASSETTE

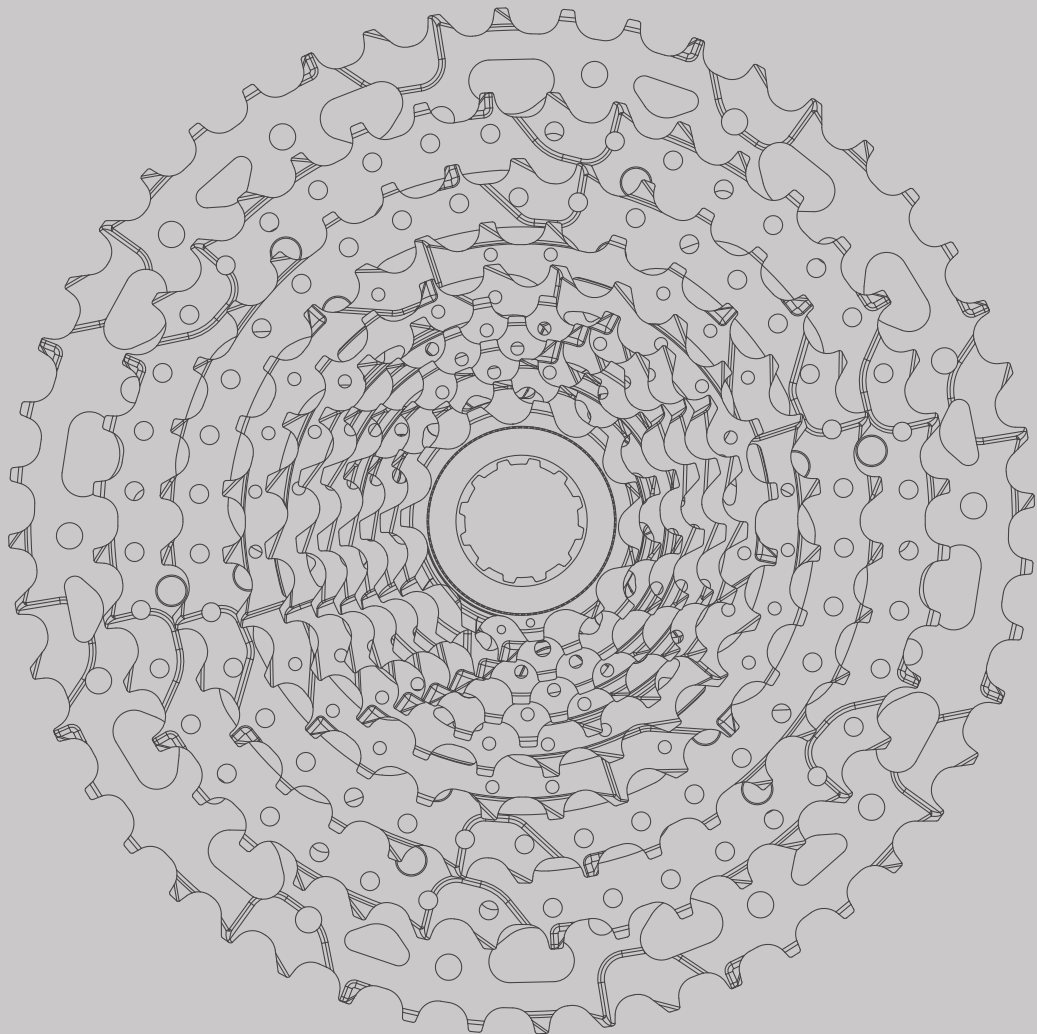

# Important Notice



## REMINDER

Before installing the products, please read and understand the installation procedures. Improper installation can lead to premature product failures or even injuries. If you have any questions on how to install, please contact us or consult with a professional bicycle mechanic.

# INDEX

<b>Tools and Supplies</b>	<b>3</b>
<b>Freehub Body Requirements</b>	<b>4</b>
<b>H-Series vs. G-Series Cassette</b>	<b>6</b>
<b>Cassette Installation</b>	<b>7</b>
Lockring Installation	9
Check for Cassette Free Play	11
<b>Cassette Removal</b>	<b>12</b>
Looseing the Lockring	12
Cassette Removal	14
<b>Installation Order</b>	<b>15</b>
Standard HG Freehub	16
11-Speed	16
10-Speed	18
9-Speed	21
8-Speed	22
7-Speed	23
Road 11-Speed HG Freehub	24
11-Speed	24
10-Speed	28
9-Speed	31
8-Speed	32
7-Speed	33

# Tools and Supplies

1. Large sized wrench or torque wrench
2. Cassette locking tool
3. Grease
4. Chain whip

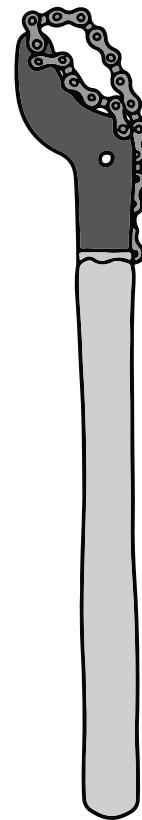
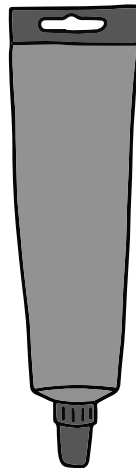
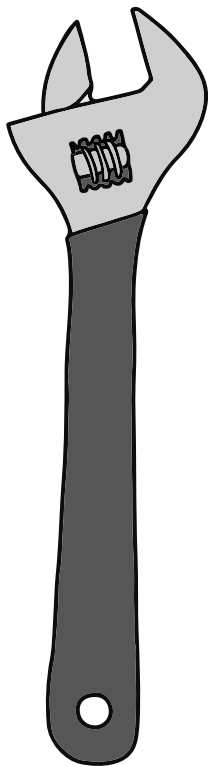



## Standard 8 / 9 / 10 Speed Freehub Body

All microSHIFT MTB (8, 9, 10, 11 speed) cassettes and (8, 9, 10 speed) road cassettes fit directly on a **standard 8/9/10 speed HG freehub body (length 34.90 mm)**.

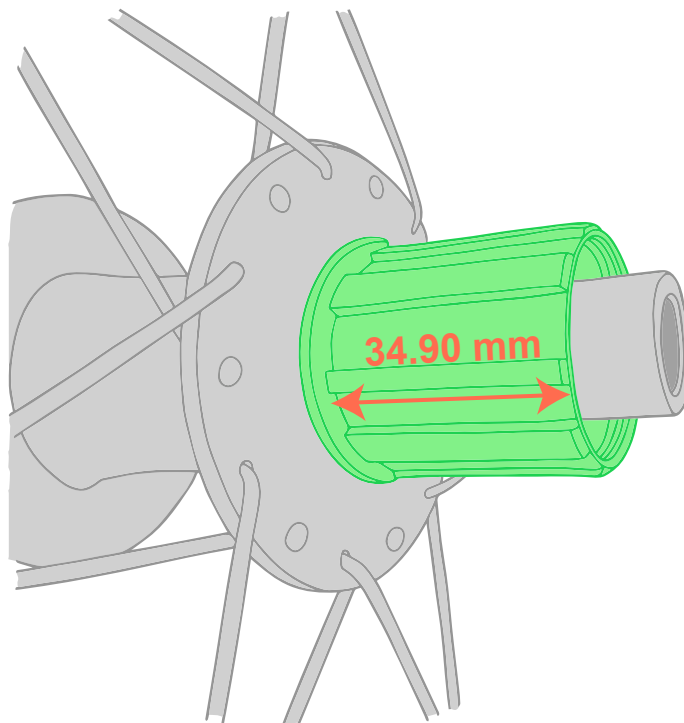

## Road 11-Speed Freehub Body

To install 11-speed road cassettes on the newer **11-speed road HG freehub body (length 36.75 mm)**, install the cassette directly. No spacer is needed.

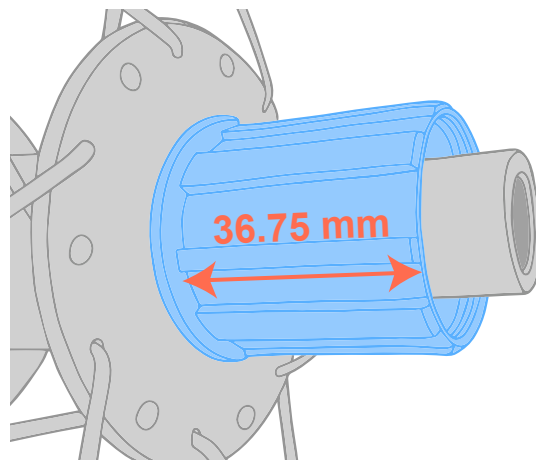

To fit MTB microSHIFT (8, 9, 10, 11 speed) cassettes and (8, 9, 10 speed) road cassettes, add a **1.85mm spacer** before installing the cassette.

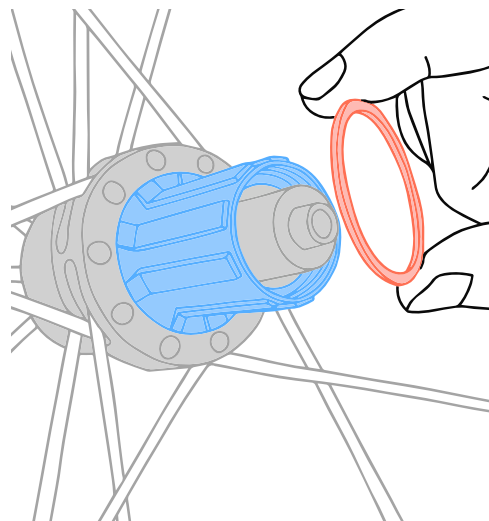

# H-series vs. G-series Cassettes

**H-series** cassettes use individual steel cogs connected with **two or three pins** for easy assembly.

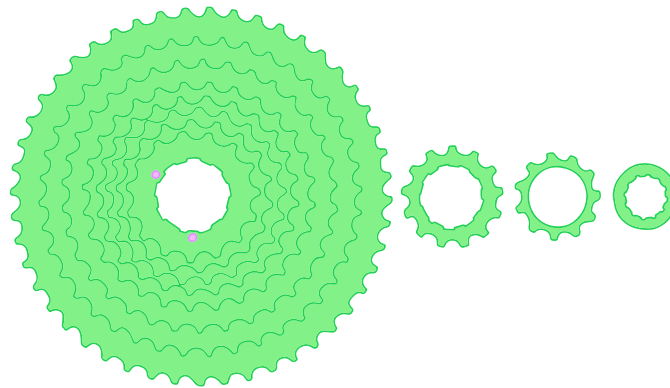

**G-series** cassettes use one or more **aluminum spiders** to mount multiple cogs, with smaller cogs loaded individually on top.

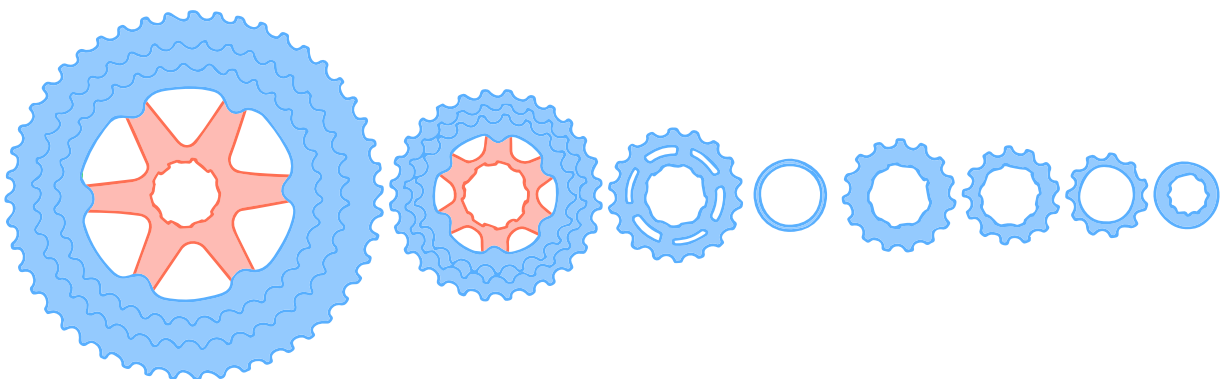



## 11-Speed Road Freehub Body Only

To install the 8, 9, 10 speed cassette on the wider 11-speed road freehub body, slot in a **1.85 mm cassette spacer** before you install the cassette.

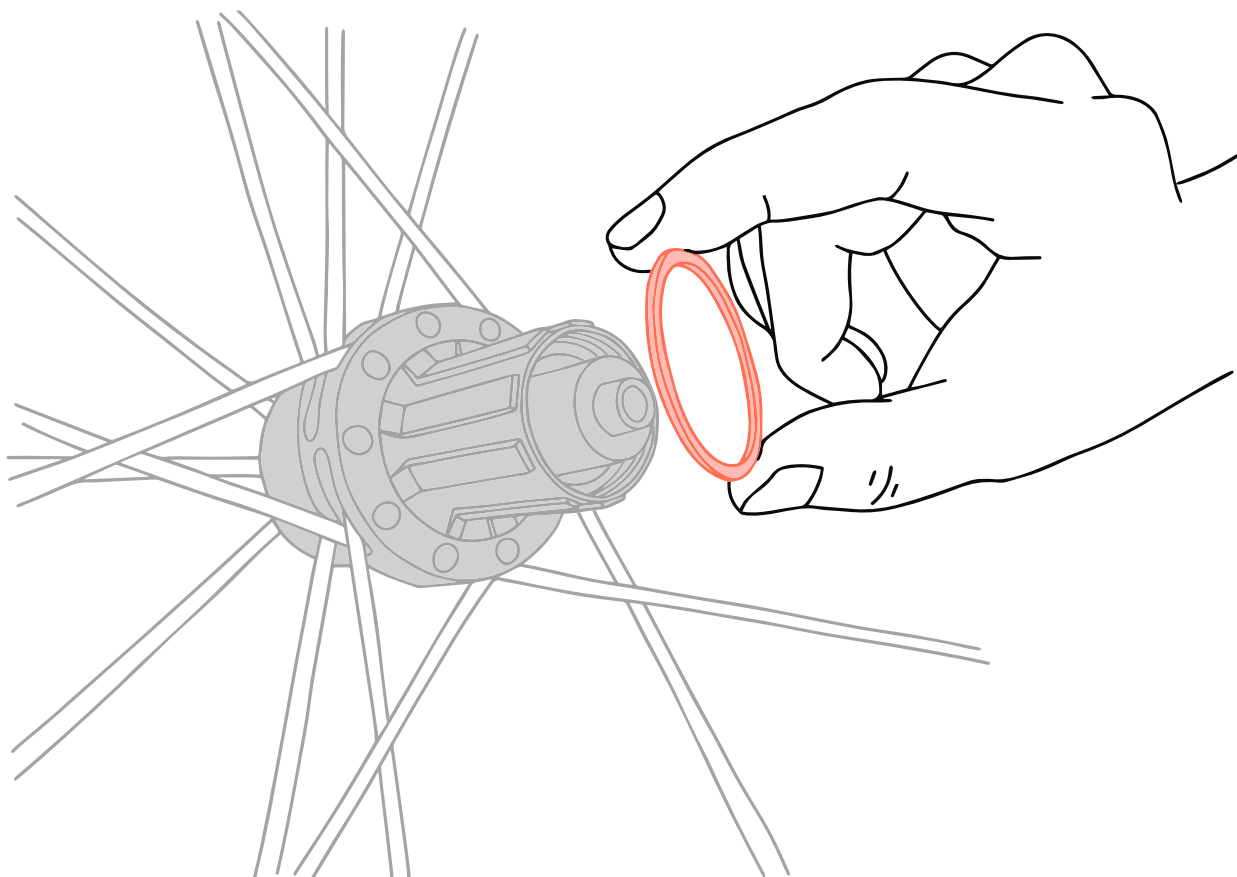



Align the **small spline** on the freehub body with the **small spline recess** on each cassette component, then slide on each component in order as shown in the **Installation Order** section of this manual.

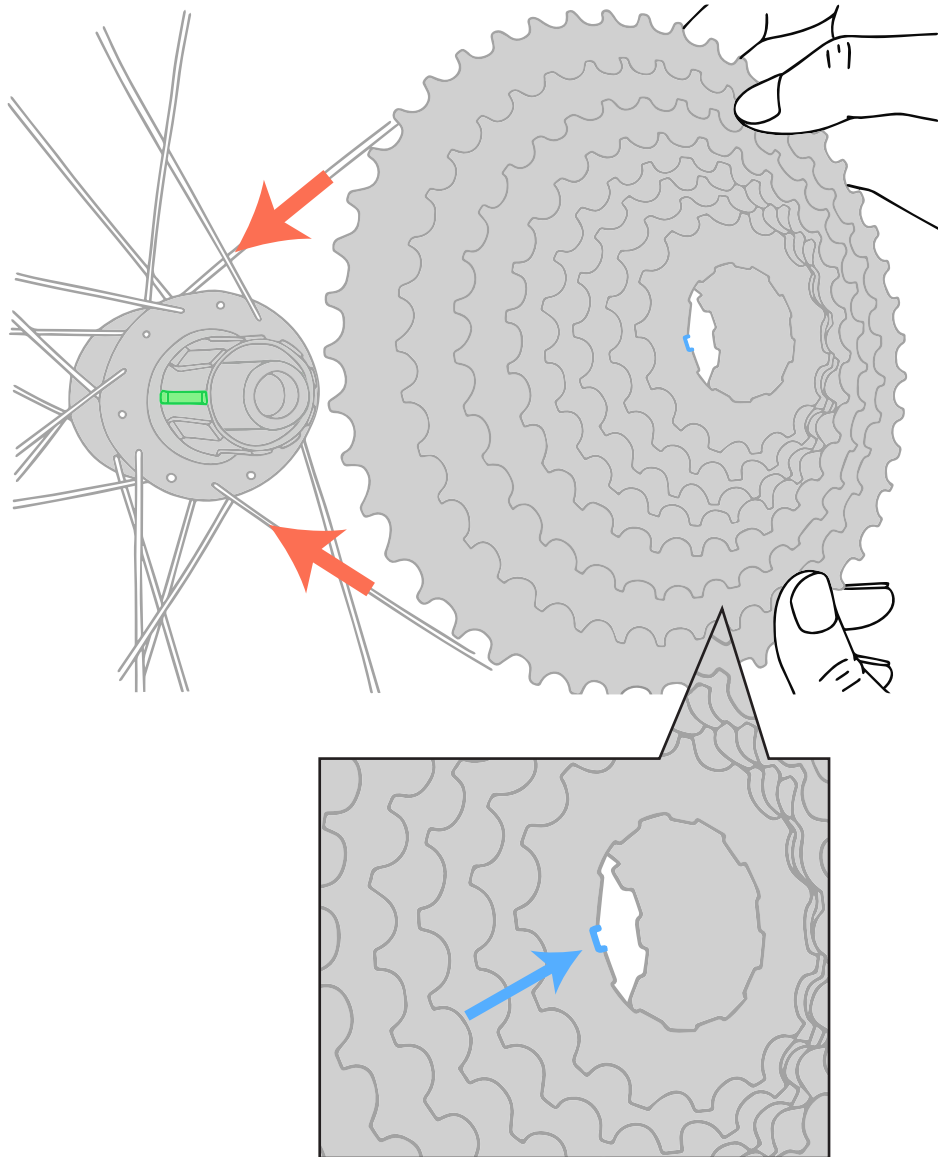

# Lockring Installation

Part I

Apply **grease** to the **lockring thread** on the inside of the freehub body.

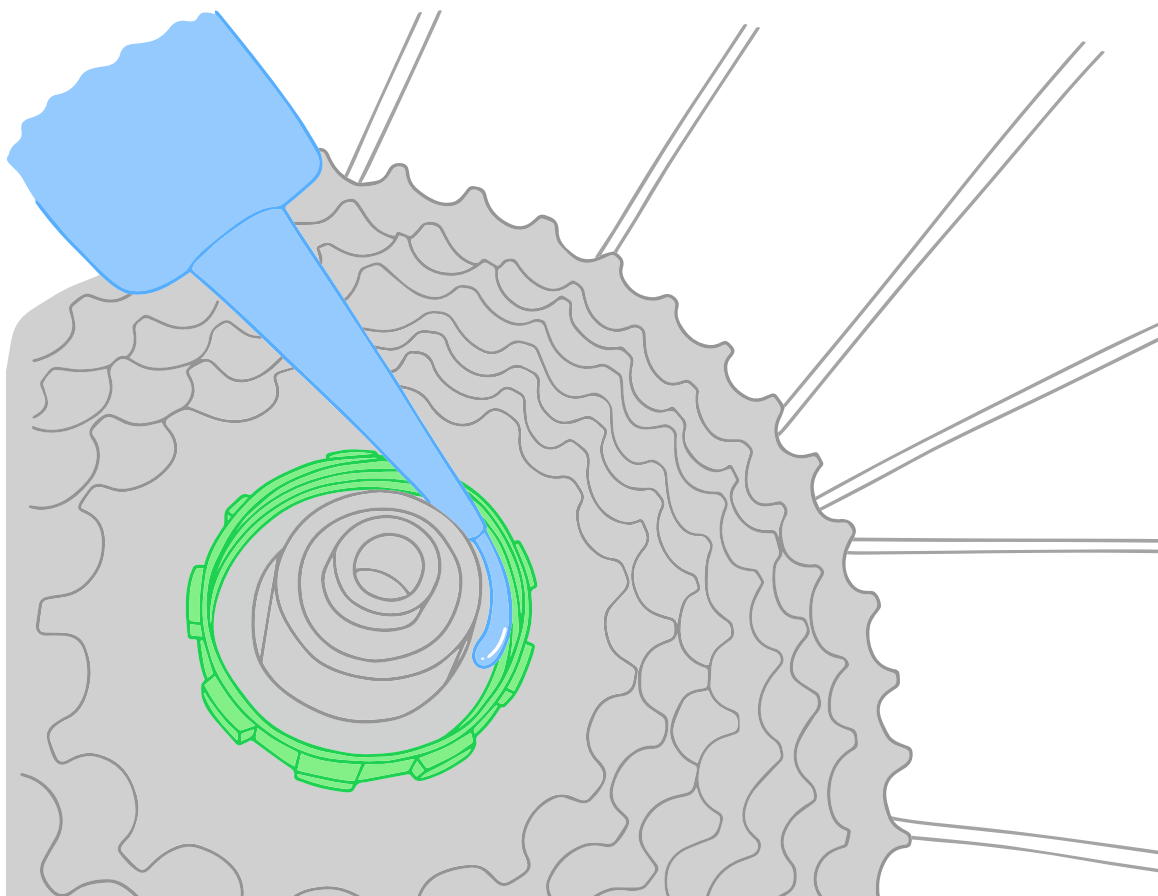

# Lockring Installation

Part II

Thread on the lockring using a **lockring tool** and a **large sized wrench**. Tighten the lockring to **40 Nm**.

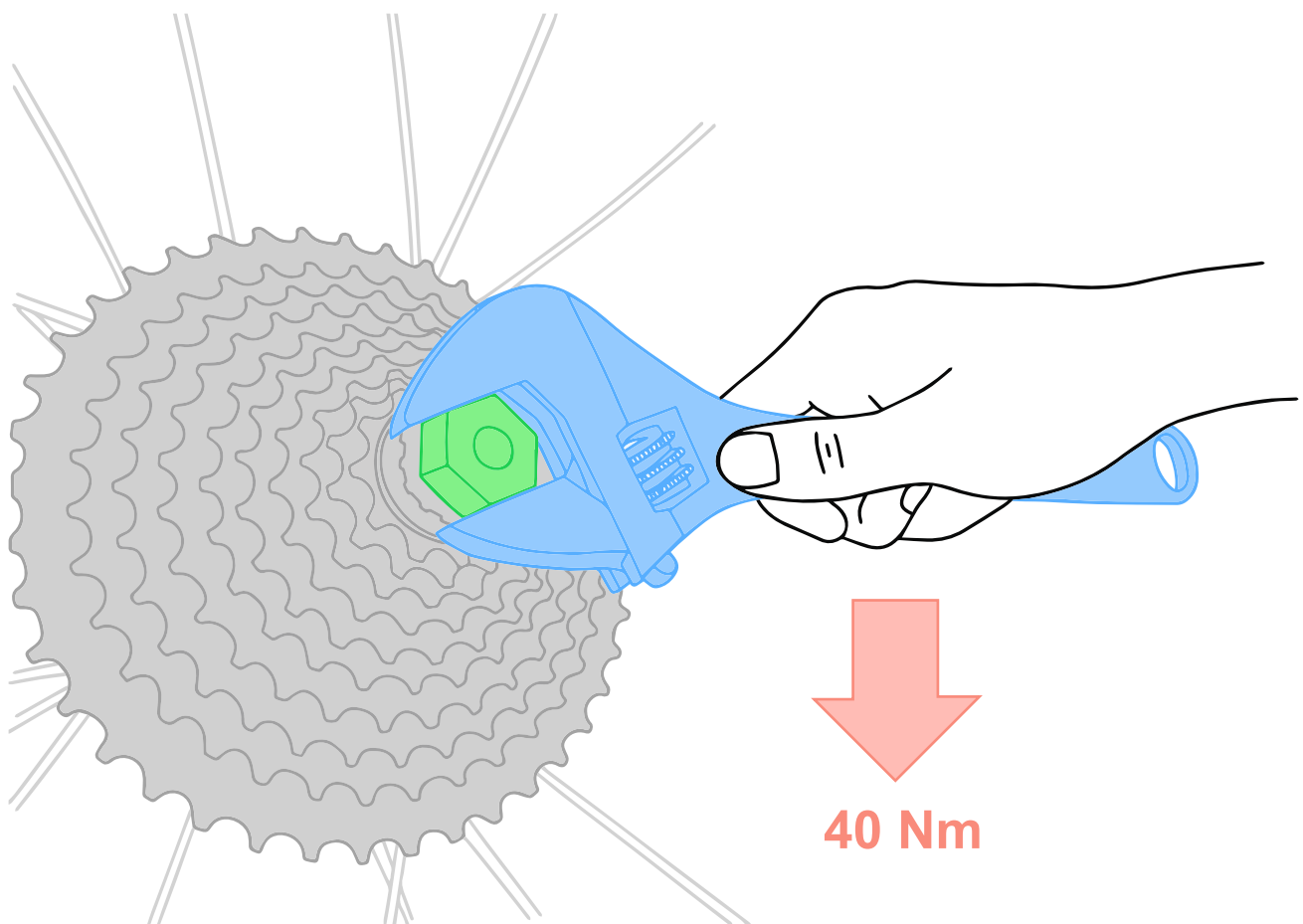

## Check for Cassette Free Play

There should be no free play in the cassette cogs after the lock ring is tightened.

If there is play, double check the **Installation Order** of the cassette. Make sure the correct spacers and cassette components are installed.

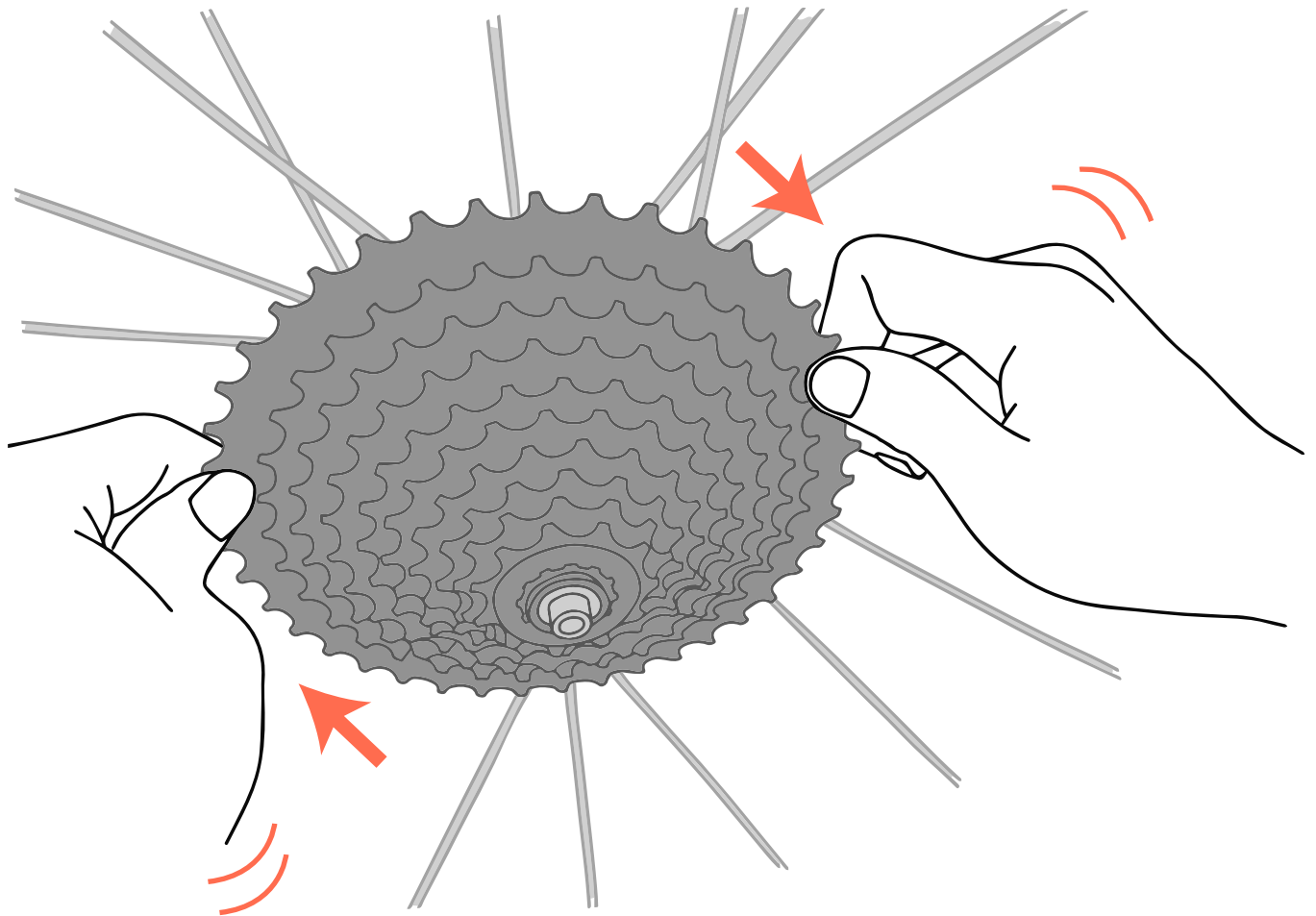

# Loosening the Lockring

Part I

Begin by placing a **chain whip** on the cassette cog. Place the **cassette lockring tool** into the lockring.

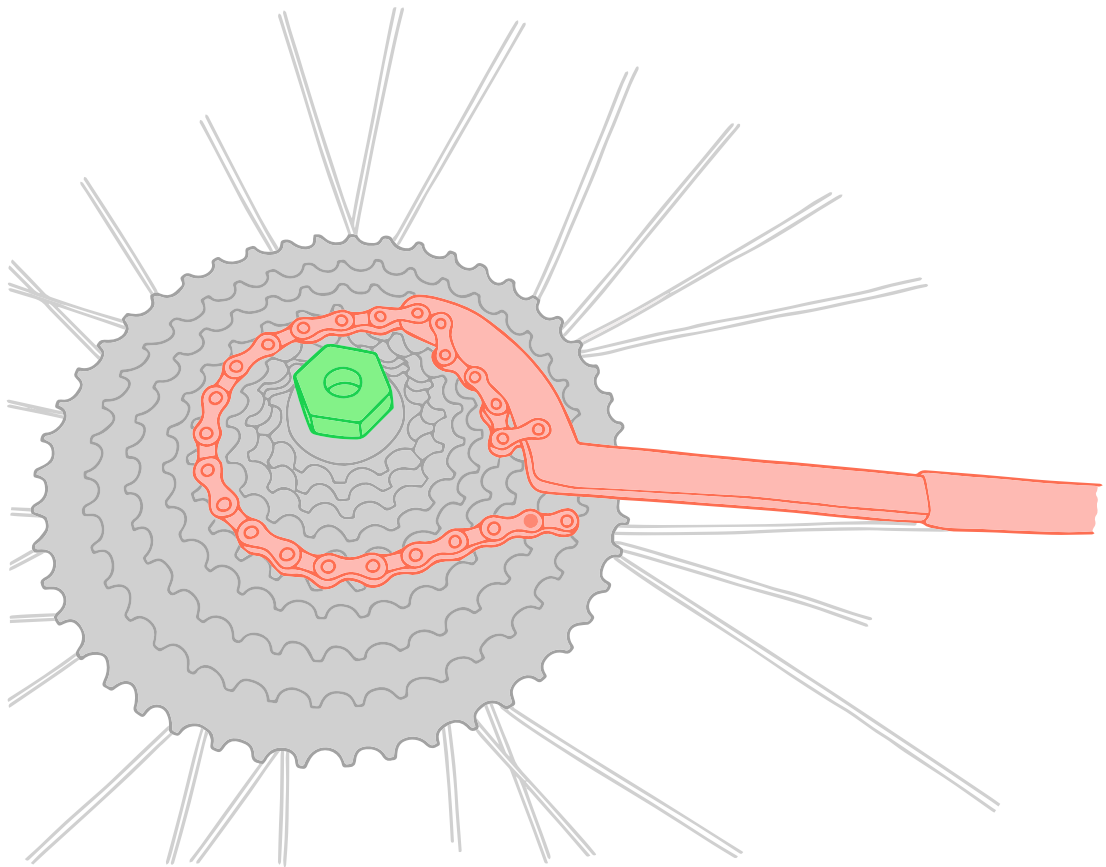

# Loosening the Lockring

Part II

While hold the cassette in place with the **chain whip**, turn the **lockring tool** counter-clockwise using a **large sized wrench**.

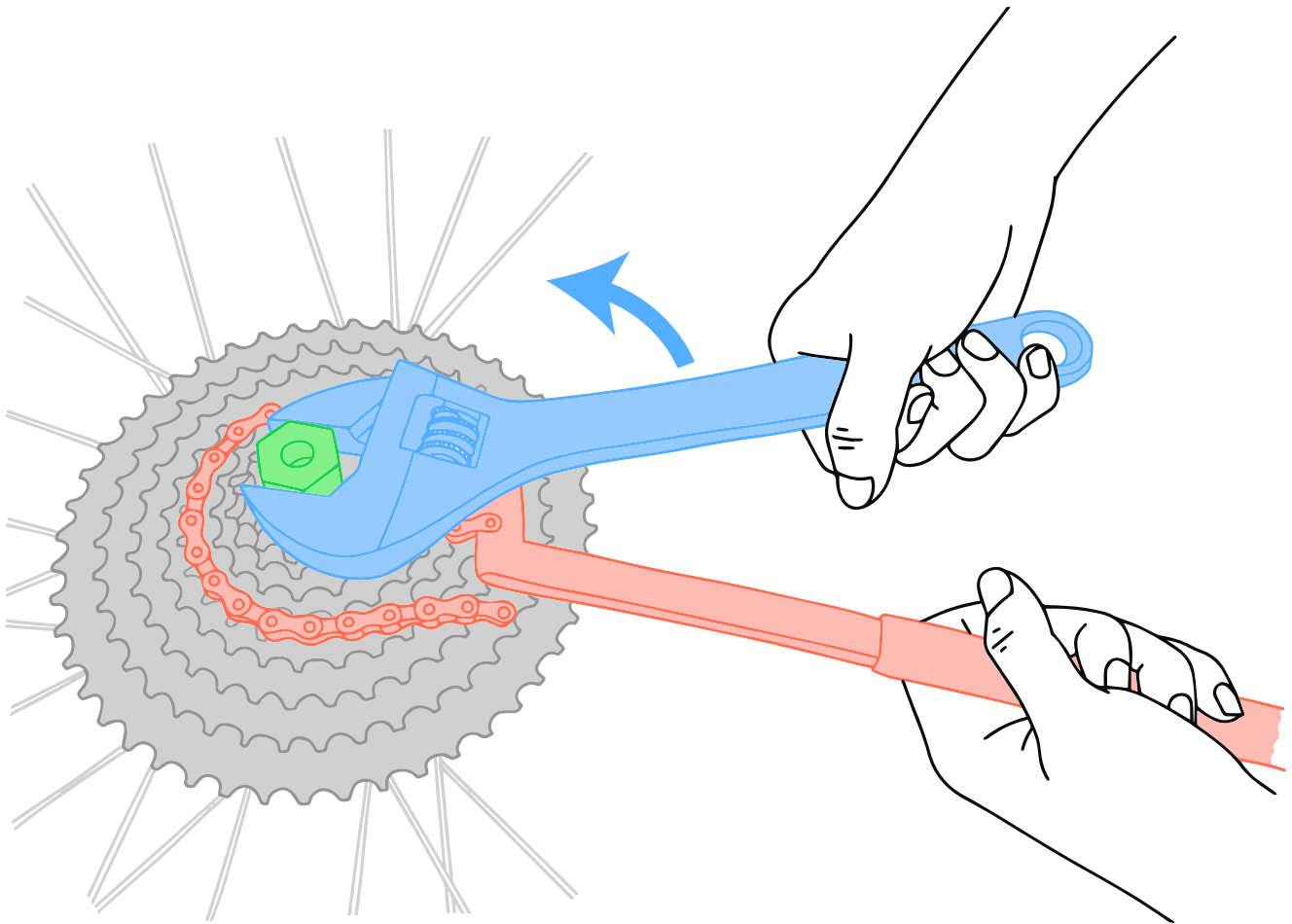

Once the lock ring is removed, pull the cassette away from the hub.

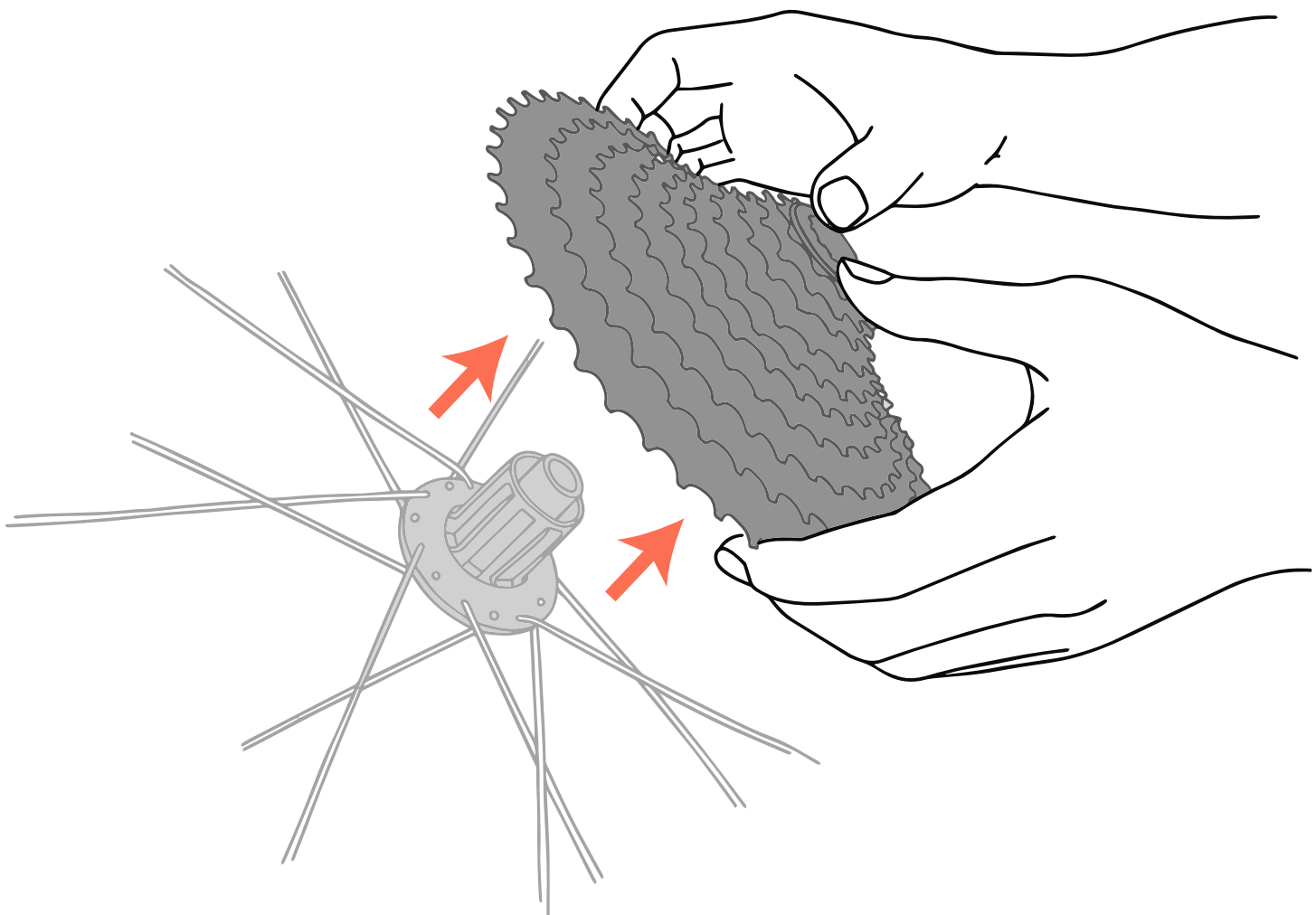

# Installation Order Index

<b>Standard HG Freehub</b>	<b>16</b>
11-Speed	16
10-Speed	18
9-Speed	21
8-Speed	22
7-Speed	23
<b>Road 11 Speed HG Freehub</b>	<b>24</b>
11-Speed	24
10-Speed	28
9-Speed	31
8-Speed	32
7-Speed	33



# 11-Speed (Standard HG Freehub)

**Models:**

CS-H113 11-46  
CS-H113 11-42  
CS-H113 11-40

CS-H113A 11-46  
CS-H113A 11-40

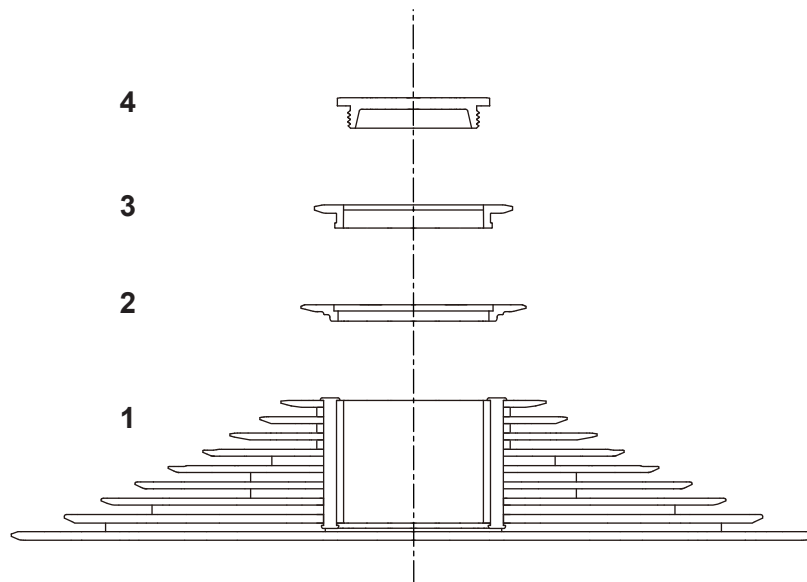

# 11-Speed (Standard HG Freehub)

**Models:**

CS-G113 11-46

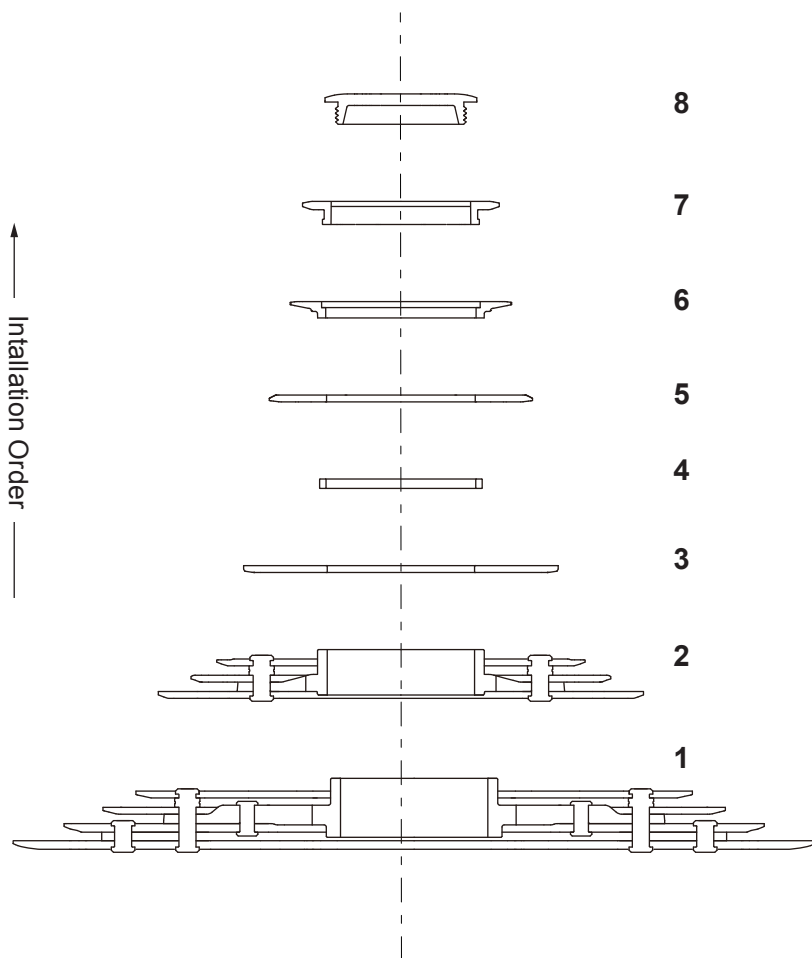

**Models:**

CS-G113 11-40  
CS-G113 11-42

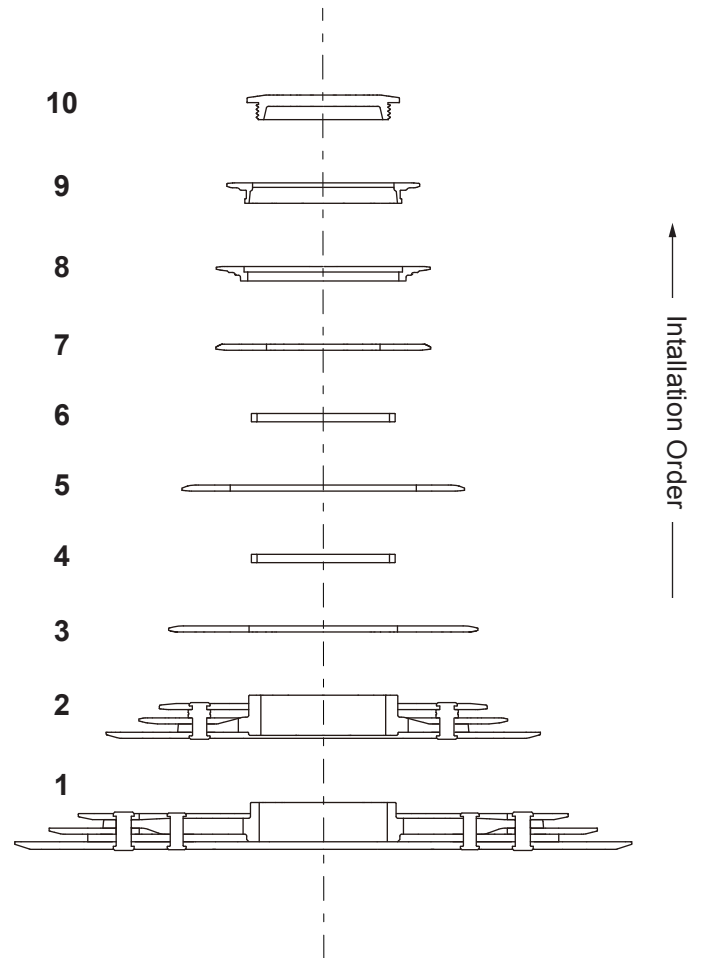

# 10-Speed (Standard HG Freehub)

## Models:

CS-H100 11-36

CS-H103 11-40

CS-H104 11-48

CS-H103A 11-42

## Models:

CS-H100 11-25

CS-H100 11-28

CS-H100 11-32

CS-H100 11-34

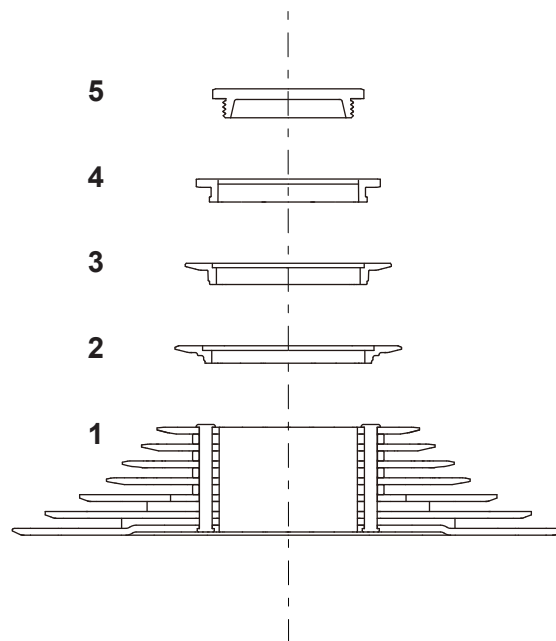
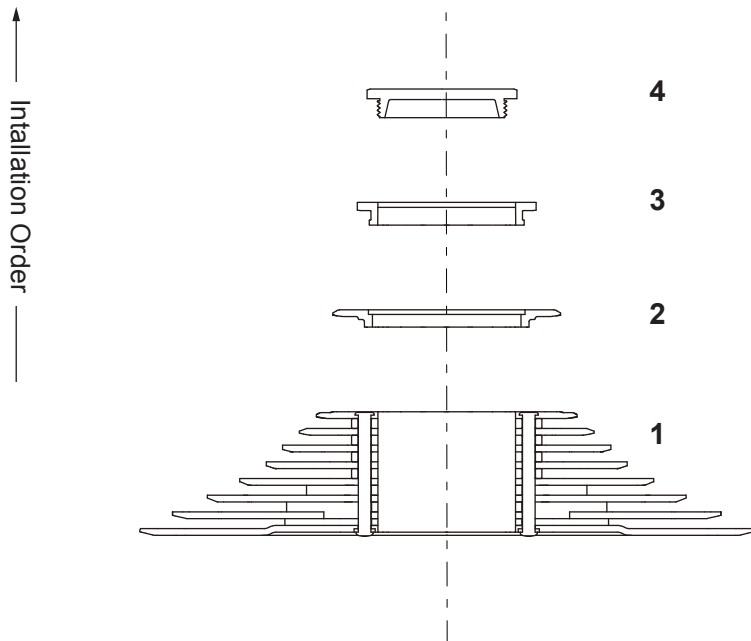

# 10-Speed (Standard HG Freehub)

**Models:**

CS-G104 11-48

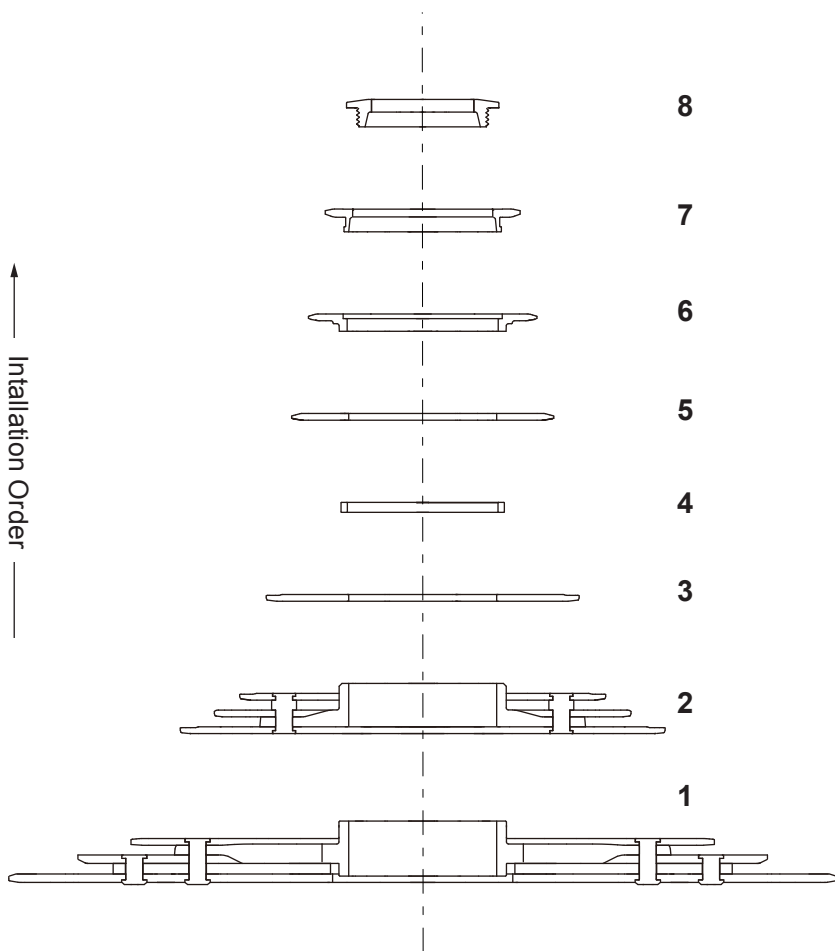

**Models:**

CS-G100 11-36

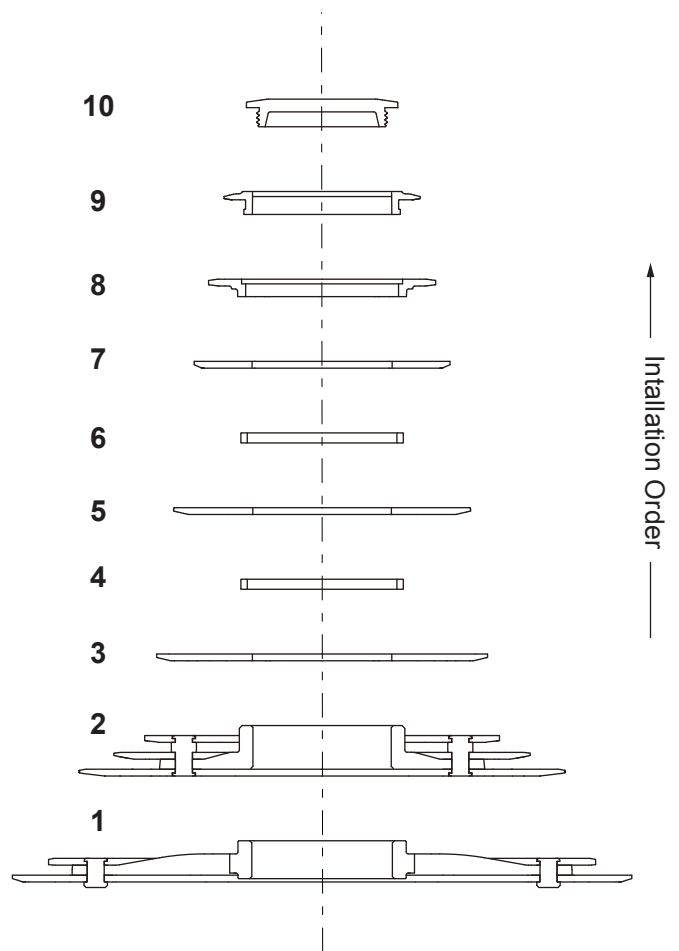

# 10-Speed (Standard HG Freehub)

**Models:**  
CS-G100 11-25

**Models:**  
CS-G100 11-28

↑ Installation Order

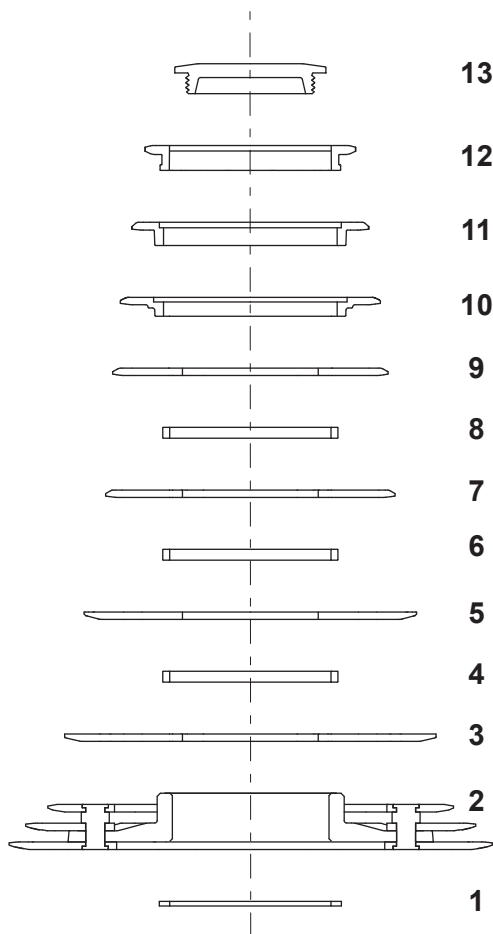

↑ Installation Order

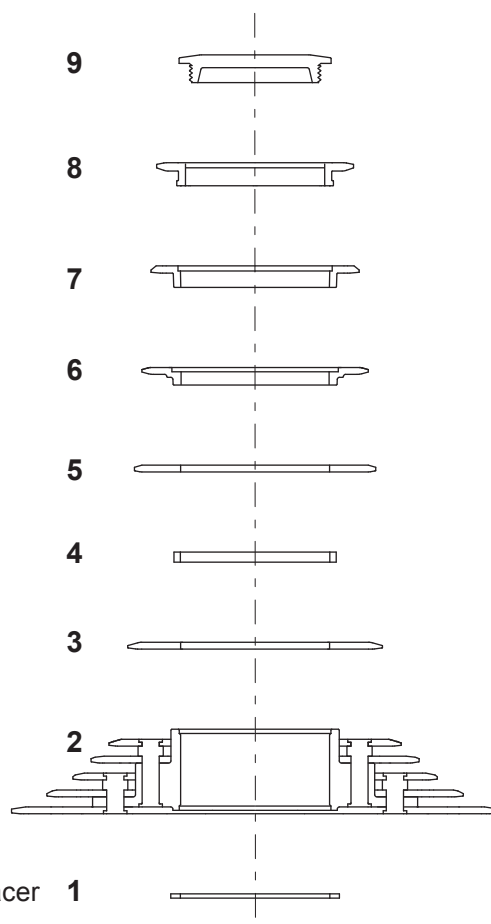

# 9-Speed (Standard HG Freehub)

**Models:**

CS-H092 12-25  
CS-H092 12-36  
CS-H092 11-32  
CS-H092 11-34  
CS-H092 11-36

CS-H093 11-34  
CS-H093 11-42  
CS-H093 11-46

CS-H094 11-42

CS-H093A 11-42

**Models:**

CS-H092 11-25  
CS-H092 11-28

↑ Installation Order

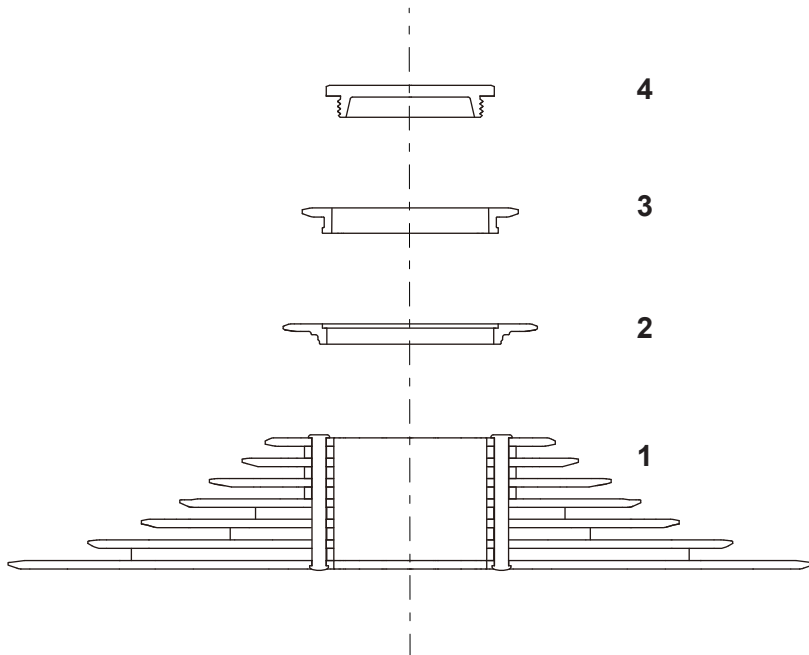

↑ Installation Order

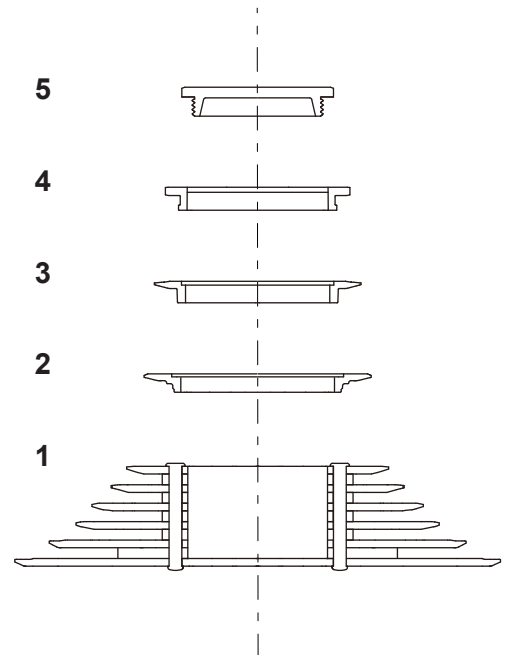

# 8-Speed (Standard HG Freehub)

**Models:**

CS-H081 12-42

CS-H083 12-42

CS-H083 12-46

CS-H084 12-42

**Models:**

CS-H081 11-28

CS-H081 11-32

CS-H081 11-34

CS-H081 12-25

CS-H081 12-28

CS-H081 12-32

CS-H082 11-28

CS-H082 11-32

CS-H082 11-34

CS-H082 12-25

CS-H082 12-28

CS-H082 12-32

↑ Installation Order

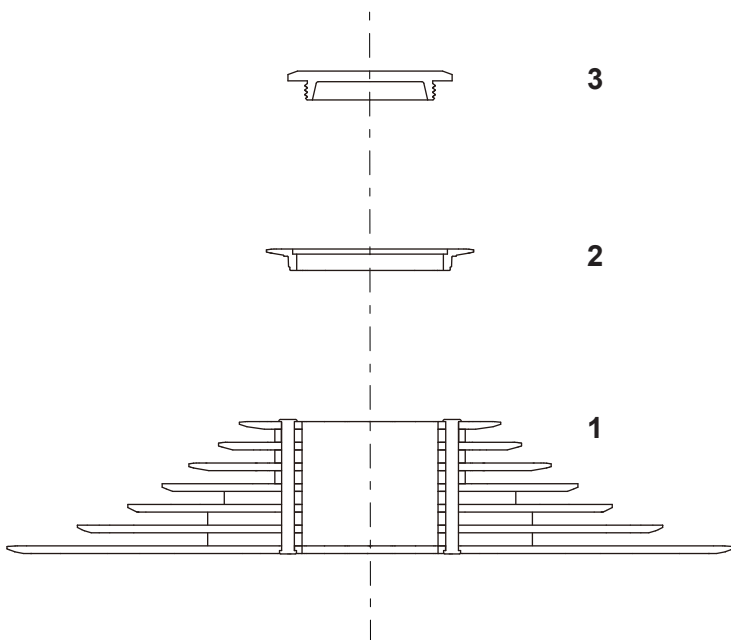

↑ Installation Order

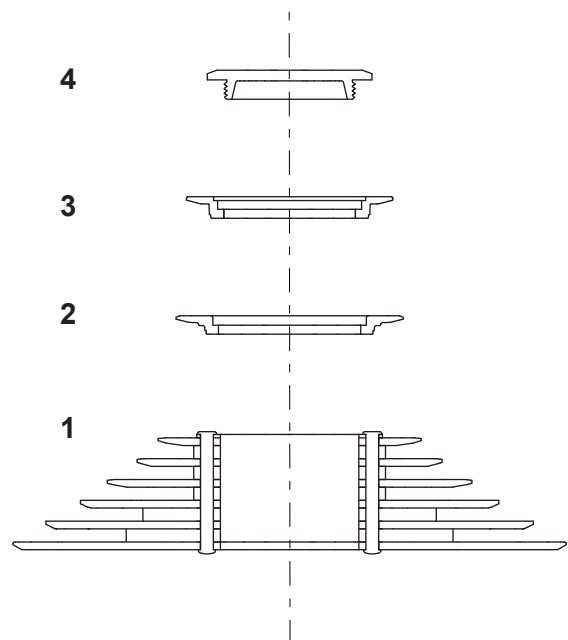

# 7-Speed (Standard HG Freehub)

**Models:**

CS-H071 12-28

CS-H071 12-32

CS-H072 12-28

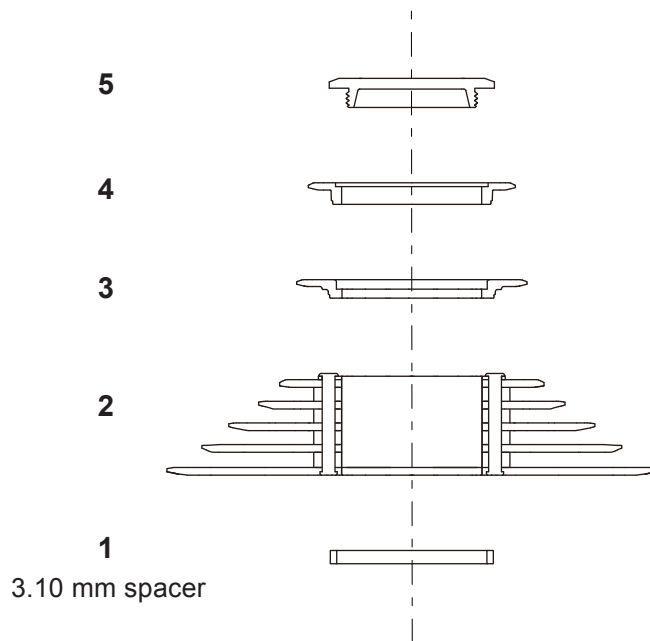



# 11-Speed (Road 11-Speed HG Freehub)



**Not compatible with Standard HG Freehub**

## Models:

CS-H110 11-25  
CS-H110 11-28  
CS-H110 11-32  
CS-H110 11-34

↑ Installation Order

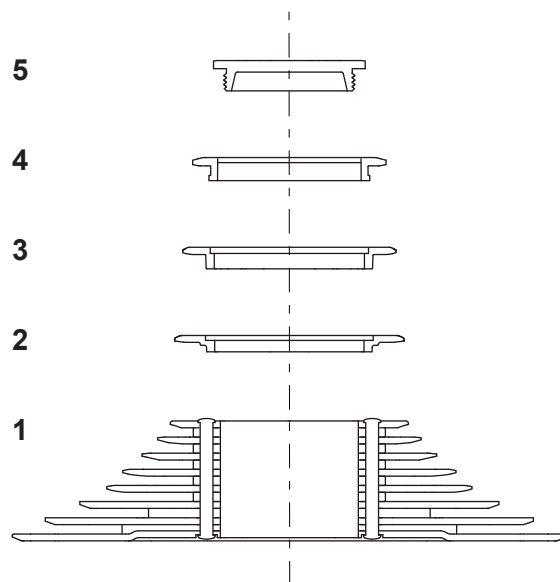

↑ Installation Order

# 11-Speed (Road 11-Speed HG Freehub)



**Not compatible with Standard HG Freehub**

**Models:**

CS-G110 11-25  
CS-G110 11-28

**Models:**

CS-G110 11-32

↑ Installation Order ↓

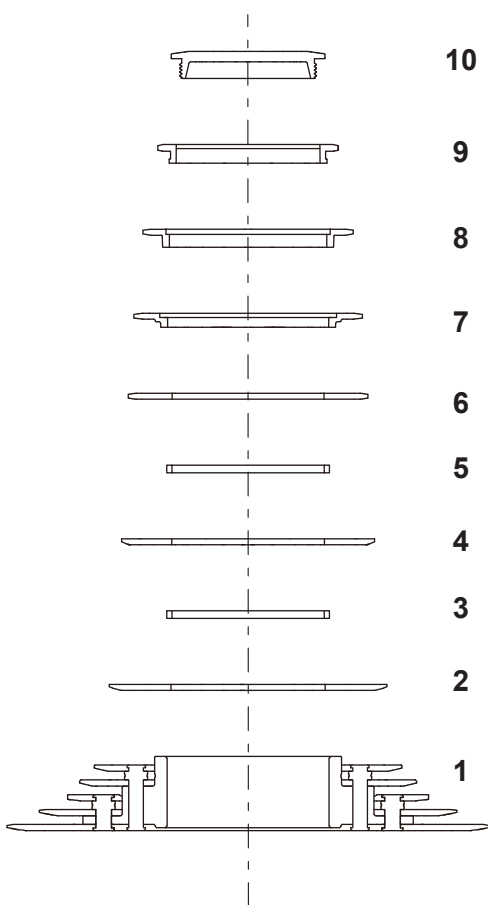

↑ Installation Order ↓

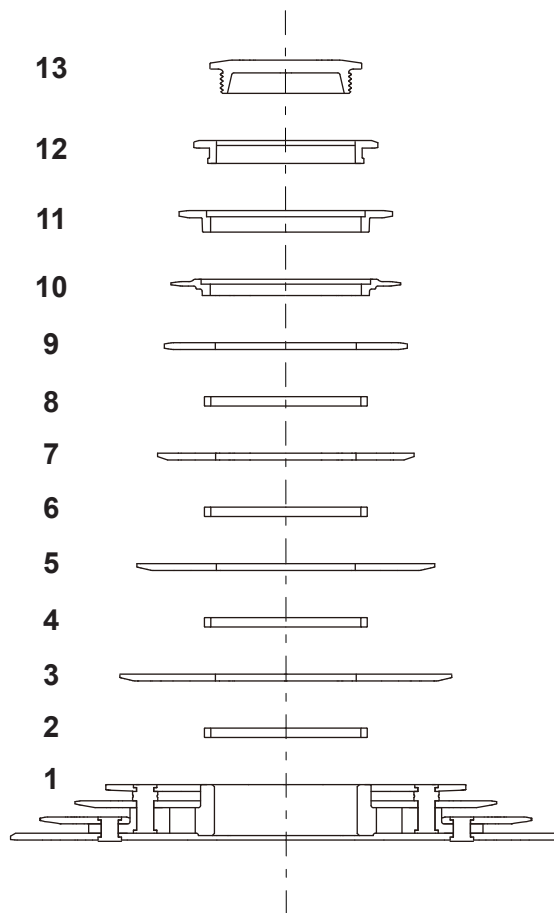

# 11-Speed (Road 11-Speed HG Freehub)

**Models:**

CS-G113 11-46

**Models:**

CS-G113 11-40  
CS-G113 11-42

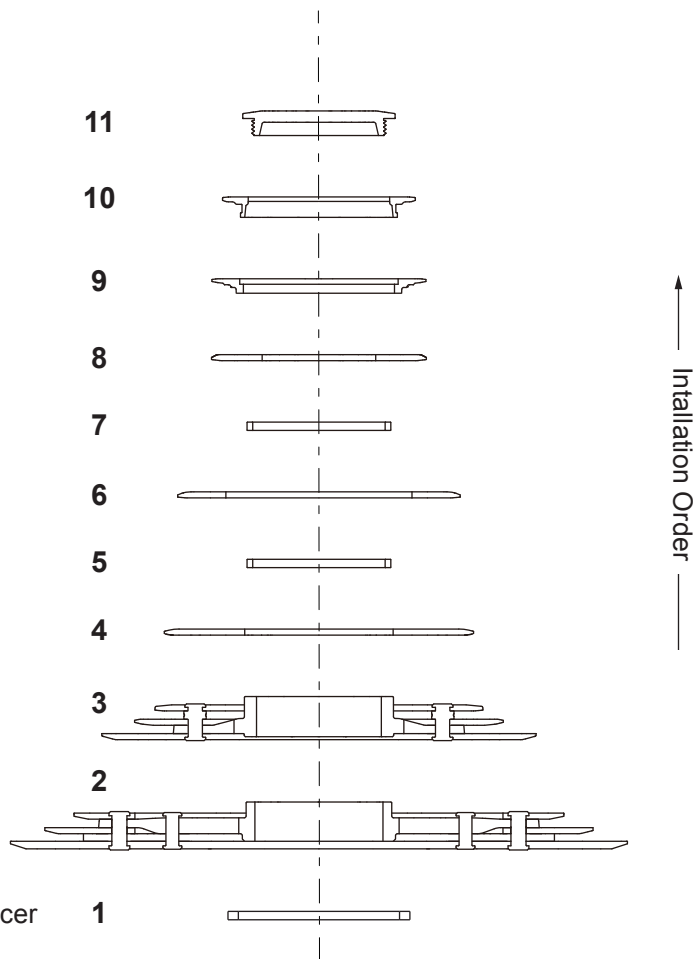
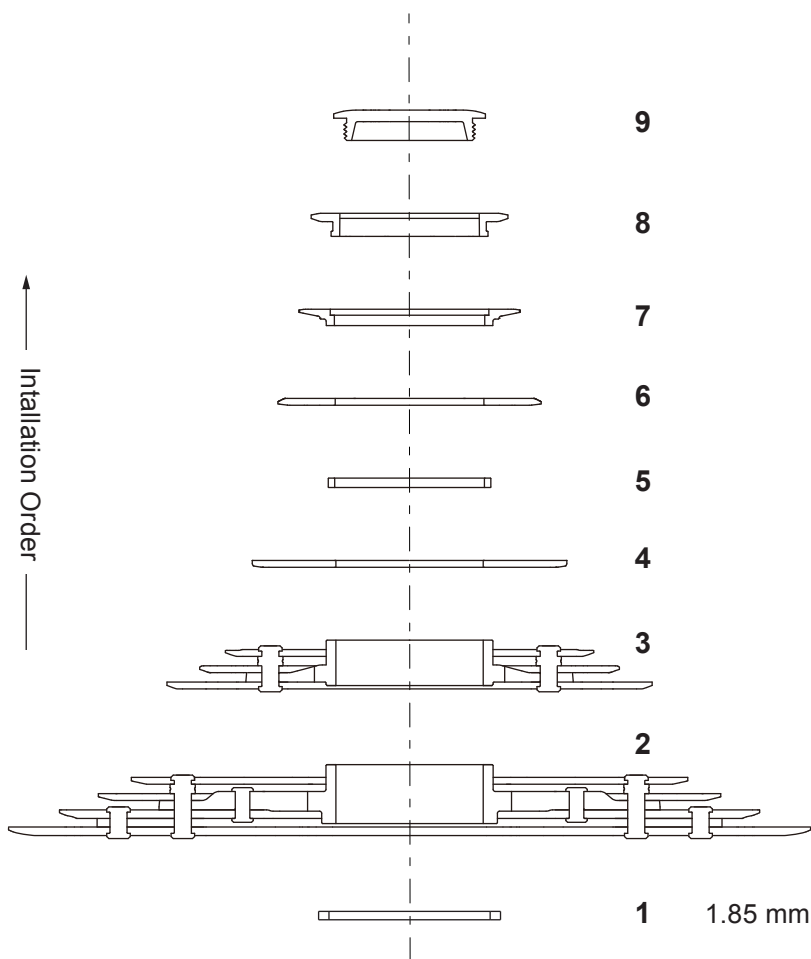

# 11-Speed (Road 11-Speed HG Freehub)

**Models:**

CS-H113 11-46

CS-H113 11-42

CS-H113 11-40

CS-H113A 11-46

CS-H113A 11-40

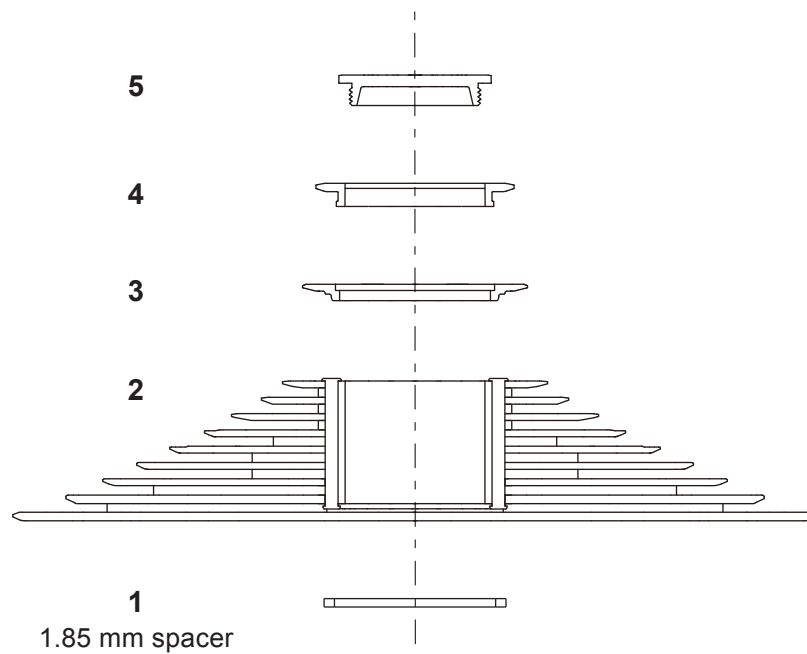

# 10-Speed (Road 11-Speed HG Freehub)

**Models:**

- CS-H100 11-36
- CS-H103 11-40
- CS-H104 11-48
- CS-H103A 11-42

**Models:**

- CS-H100 11-25
- CS-H100 11-28
- CS-H100 11-32
- CS-H100 11-34

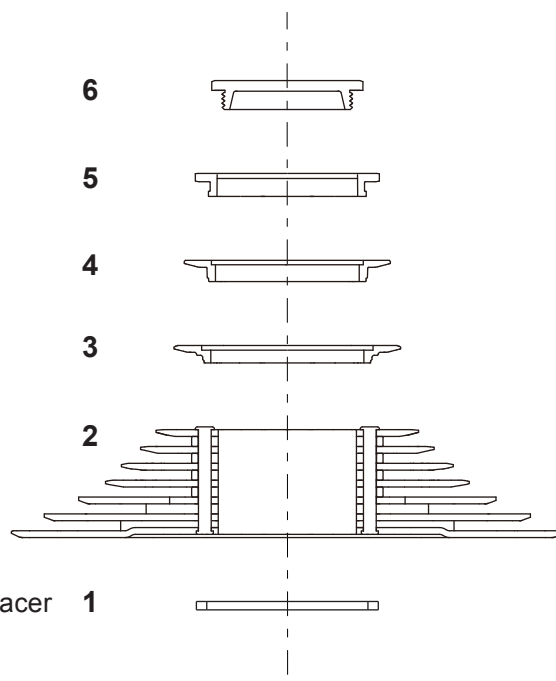
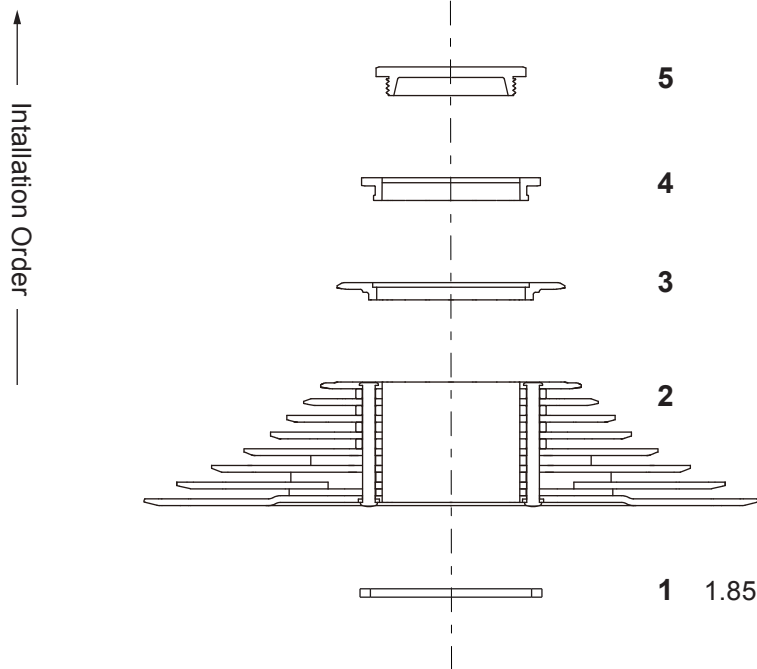

# 10-Speed (Road 11-Speed HG Freehub)

**Models:**  
CS-G104 11-48

**Models:**  
CS-G100 11-36

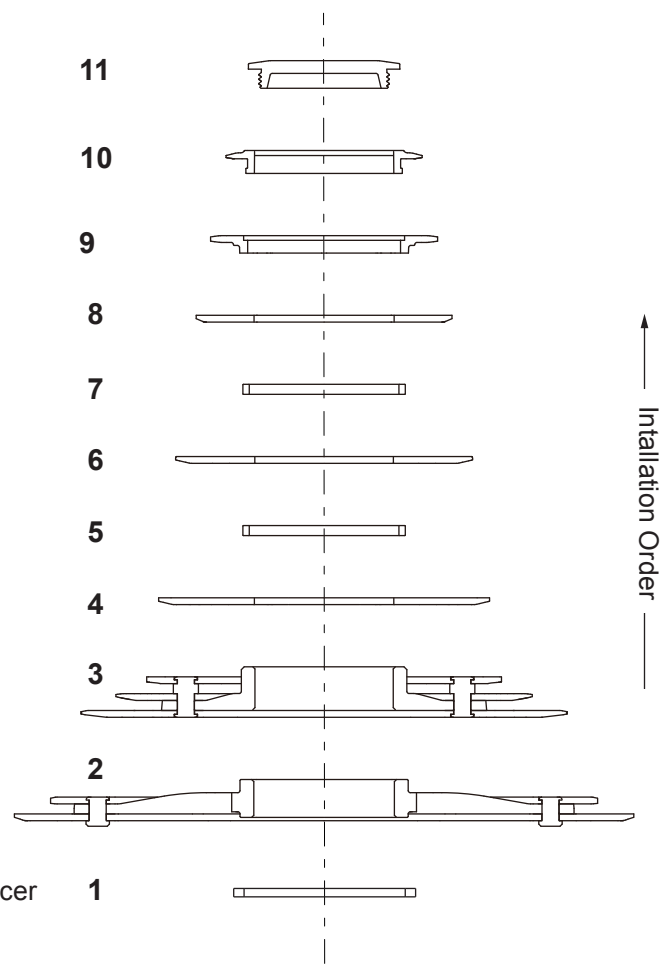
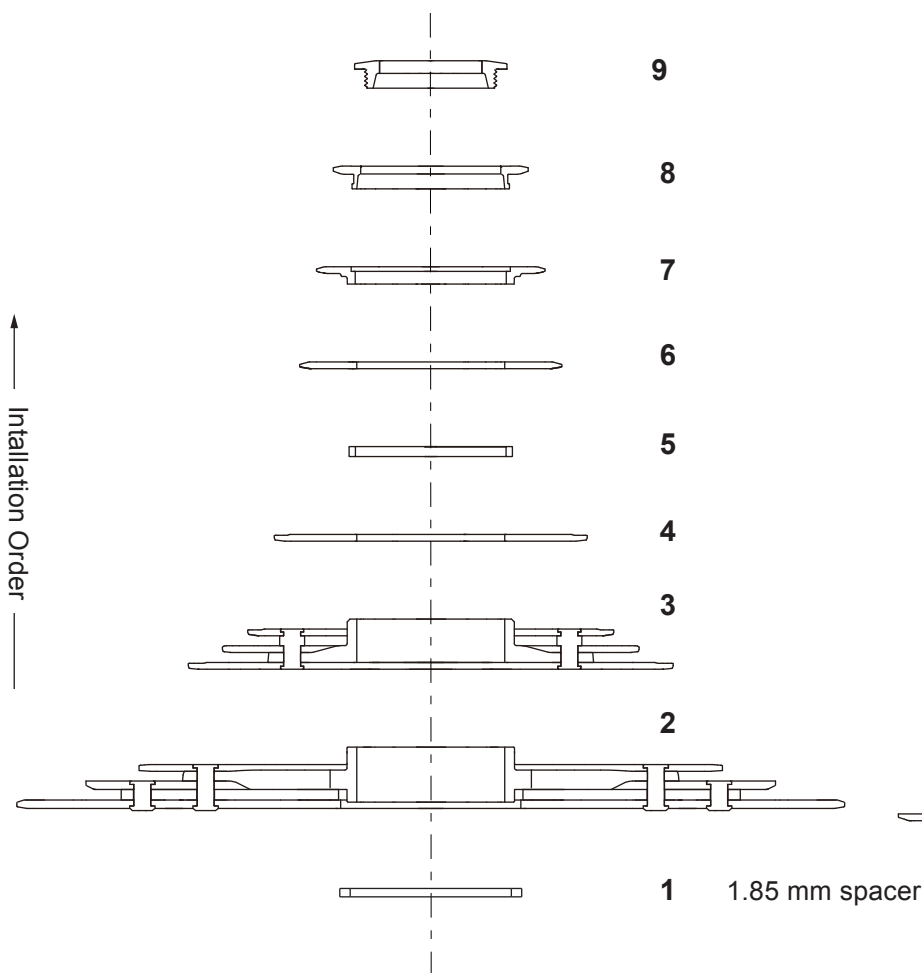

# 10-Speed (Road 11-Speed HG Freehub)

**Models:**  
CS-G100 11-25

**Models:**  
CS-G100 11-28

↑ Installation Order

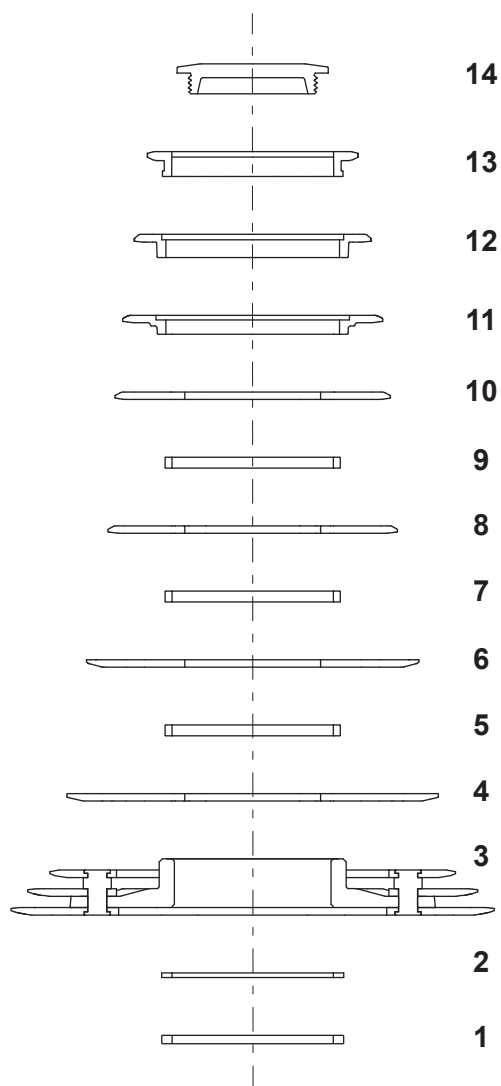

1 1.85 mm spacer

↑ Installation Order

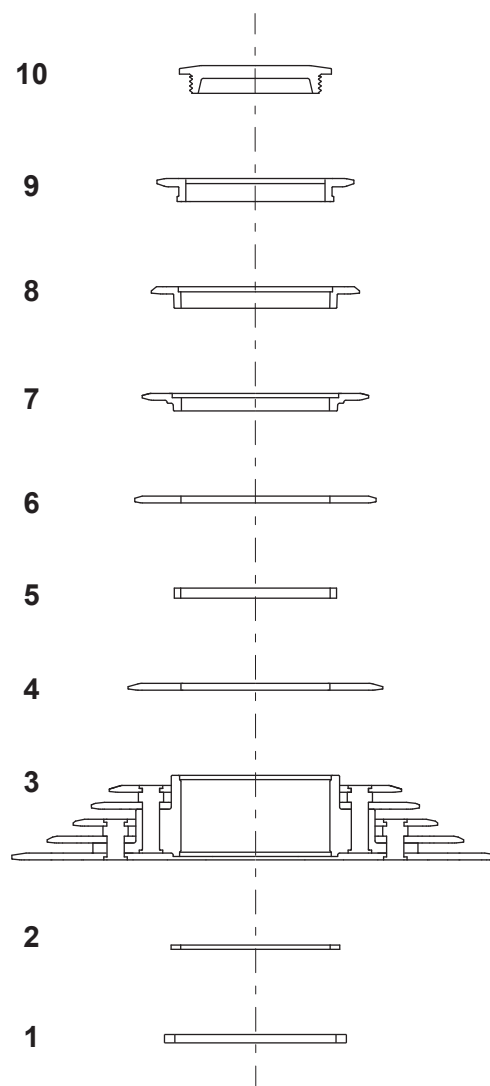

# 9-Speed (Road 11-Speed HG Freehub)

**Models:**

- CS-H092 12-25
- CS-H092 12-36
- CS-H092 11-32
- CS-H092 11-34
- CS-H092 11-36
  
- CS-H093 11-34
- CS-H093 11-46
- CS-H093 11-42
  
- CS-H094 11-42
  
- CS-H093A 11-42

**Models:**

- CS-H092 11-25
- CS-H092 11-28

Installation Order

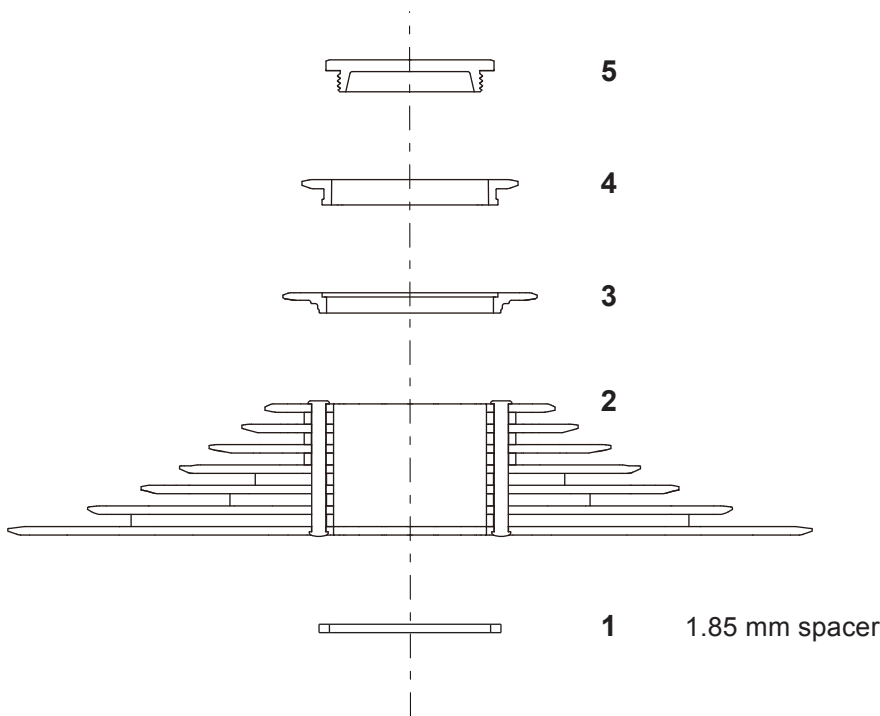

Installation Order

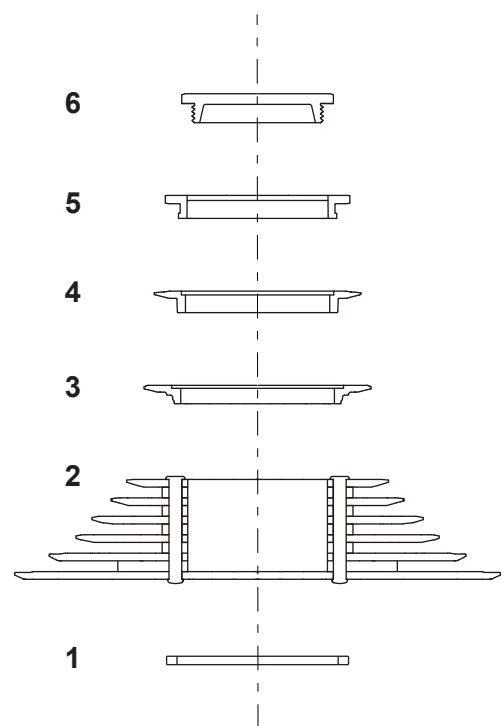



# 8-Speed (Road 11-Speed HG Freehub)

**Models:**

- CS-H081 12-42
- CS-H083 12-42
- CS-H083 12-46
- CS-H084 12-42

**Models:**

- CS-H081 11-28
- CS-H081 11-32
- CS-H081 11-34
- CS-H081 12-25
- CS-H081 12-28
- CS-H081 12-32
- CS-H082 11-28
- CS-H082 11-32
- CS-H082 11-34
- CS-H082 12-25
- CS-H082 12-28
- CS-H082 12-32

↑ Installation Order

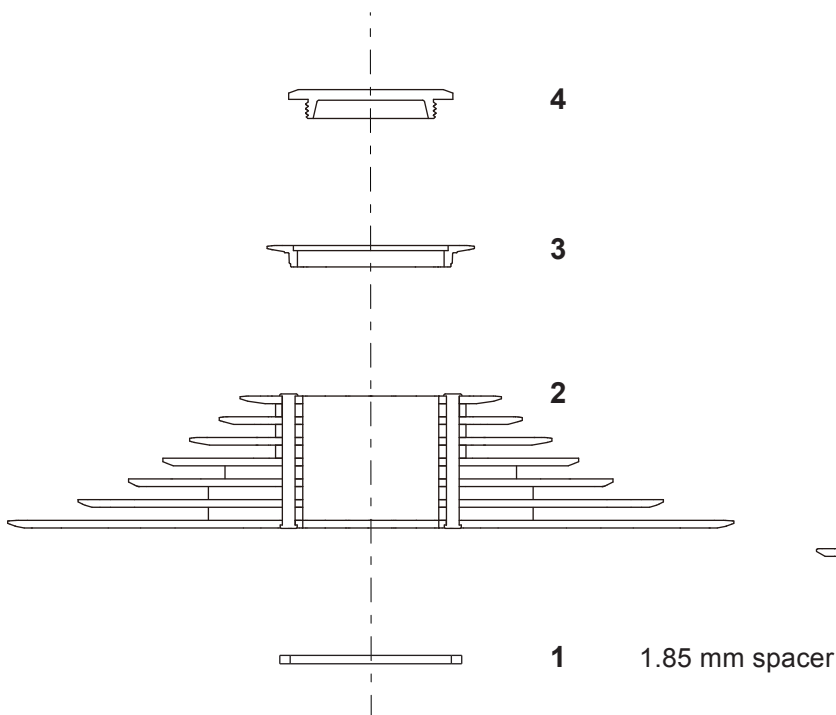

↑ Installation Order

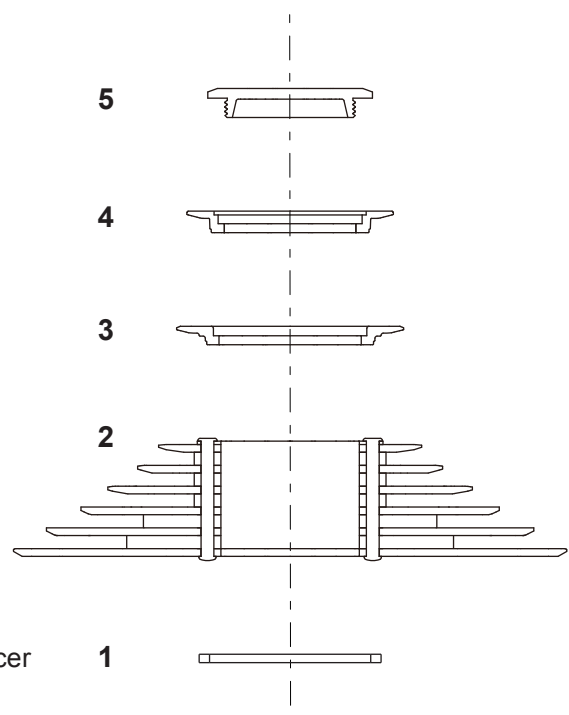

# 7-Speed (Road 11-Speed HG Freehub)

**Models:**

CS-H071 12-28

CS-H071 12-32

CS-H072 12-28

↑ Installation Order

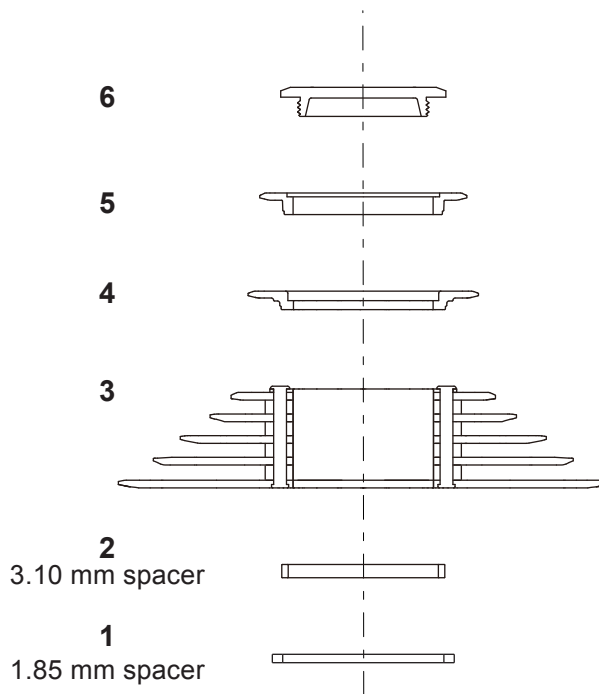

↑ Installation Order

# microSHIFT

---

[www.microSHIFT.com](http://www.microSHIFT.com)

**International**  
[service@microSHIFT.com.tw](mailto:service@microSHIFT.com.tw)

**North America**  
[service@microSHIFT.com](mailto:service@microSHIFT.com)